

PRODUCT IMAGE

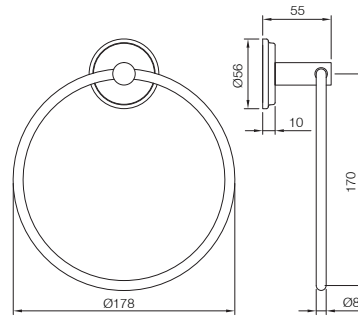

TECHNICAL DRAWING



PRODUCT DETAILS

Description	Towel Ring Round
Product Code	AEC-CHR-1121N
Connection Size (mm)	N.A
Aerator Size	N.A
Flow Rate	N.A
Flow Regulator	N.A
Recommended Water Pressure	N.A
Material Composition Specification in Percentage	<p>Brass Forgings- Cu (56.5 - 60.0), Pb (0.6 - 2.0), Fe (0.30 Max), Total Impurities excl. Fe (0.75 Max), Zn (Remainder)</p> <p>Brass Rod as per IS:319-1989- Cu (56.0-59.0), Pb (2.0-3.5), Fe (0.0-0.35), Total Impurity (0.0-0.7), Zn (Remainder)</p> <p>Brass Sheets as per IS:410-1977- Cu (61.5-64.5), Pb (0.0-0.3), Fe (0.0-0.075), Total Impurity (0.0-0.6), Zn (Remainder)</p>
Cartridge Specification	N.A
Water Tightness	N.A
Pressure Resistance	N.A
Finish	Plating: Nickel-8.0 micron Chromium-0.20 micron, Salt Spray (300 hrs+Validated), Adhesion (Pass)
Available Colour Finishing	Chrome (CHR)

DISCLAIMER: Our every effort has been made to ensure factual accuracy, the information presented subject to changes due to requirements in different sites, markets and/ or countries.110% variation in flow rate may be possible. Jaquar reserves the right to make the necessary amendments at any time without prior notice.